

WISI LR 22 6001

Fiber Node, remote-fed



Description

The LR 2x series of fiber nodes are optical nodes for HFC, RFoG or RF Overlay applications. They can be operated in RFoG (burst-mode) and HFC (continuous wave) mode.

At a glance:

- High RF output level of 117 dB μ V for coaxial distribution of FTTC or FTTB signals
- DOCSIS-3.1-compliant frequency range:
Downstream up to 1.2 GHz,
Upstream up to 204 MHz
- Pluggable duplexers enable migration towards DOCSIS 3.1 upstream
- Pluggable output splitters / taps for flexible configuration of the two RF outputs
- Device control via bluetooth app or via handset OH 41
- Optional: Remote control compliant to IEC 60728-14 via FSK receiver module
- Compact housing for outdoor deployment (IP66)
- Optical ALC for regulated output levels

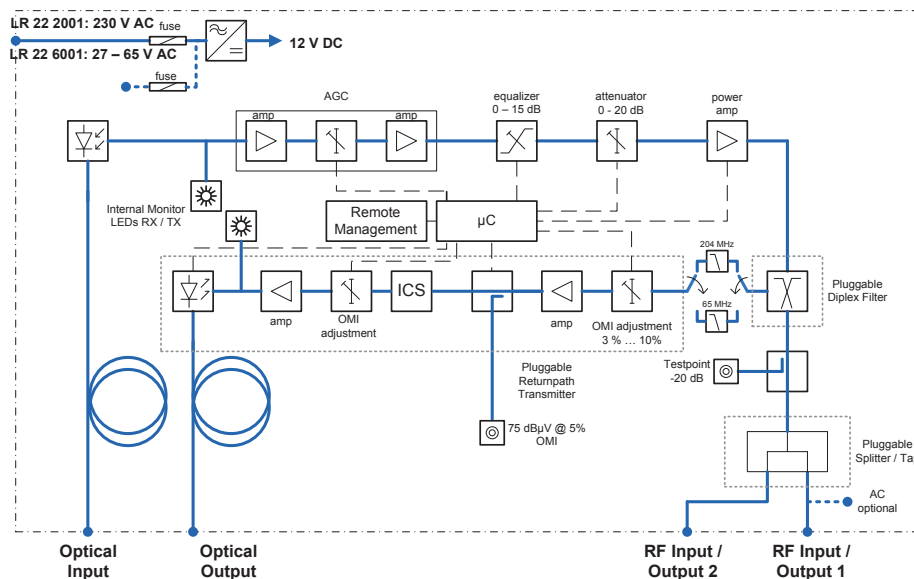

Technical data

Downstream	
Optical input power	-8...+2 dBm
Wavelength	1270...1610 nm
Frequency range	85...1218 MHz (depending on diplexer)
Noise current density	< 4,5 pA \sqrt /Hz
Attenuator downstream	0...20 dB (0,5 dB steps)
Equalizer downstream	0...15 dB (0,5 dB steps)
Output level CENELEC 42 Ch. 10 dB slope	119 dB μ V (CSO/CTB = 60 dB)
Output level CENELEC 42 Ch. flat	114 dB μ V (CSO/CTB = 60 dB)
Output level all QAM (121 QAM-256 Ch.) 10 dB slope	110 dB μ V (BER <1 exp-9), (@ 2,4% OMI)
Output level all QAM (121 QAM-256 Ch.) flat	107 dB μ V (BER <1 exp-9), (@ 2,4% OMI)
Test point	-20 dB
RF return loss	> 18 dB (-1 dB/oct., min. 14 dB)
Optical return loss	> 40 dB

Upstream

with LT 22 xxxx

Optical output power	3 dBm
Wavelength	1270...1610 nm (CWDM grid, corresponding to order code)
Frequency range	5...204 MHz (depending on diplexer)
Nominal RF input level	75 dB μ V (OMI 5%)
Attenuator range	3%...10% (OMI attenuation)
Test point	75 dB μ V (for 5% OMI per channel)
Ingress Control Switch (ICS)	0/-6/-45 dB
RF return loss	> 18 dB (-1 dB/oct., min. 14 dB)
Optical return loss	> 40 dB

Interfaces

SC/APC connectors	2 pcs. (Downstream input & upstream output separated)
RF Ports	2x PG11 (75 Ohm)
Bluetooth antenna (optional) LB 01	1x PG11

User interfaces

Status LED downstream	Optical input power
Status LED upstream	Laser activity
Management ports RJ11	1 pcs. (for handset OH 41)
Remotely controlled parameters via FSK	DS on/off, US on/off, ICS 0/-6/-45 (with optional Rx module)
Bluetooth version	4.0 / LE
Bluetooth profiles	GATT
Bluetooth transmit power	\leq 0 dBm
Bluetooth frequency	2.4 GHz
Bluetooth app compatibility	Android 4.3 or higher

General data

Supply voltage	27...65 V AC
Power consumption max.	16 W

Technical data

Dimensions (width x height x depth)	232 x 145 x 86 mm
Electro Magnetic Compatibility (EMC)	EN 50083-2
Protection class	IP 66
Ambient temperature	-20...+55 °C

LR 2X XXX1

Upstream Wavelength (see LT 22): 00 – LR 22 DS only
Power Supply: 2 – 230V local powered 6 – 65V remote powered
Typ of Node: 2 – Dual Fiber HFC Node (with LT 22)